



# PRODUCER STATEMENT – PS4 – CONSTRUCTION REVIEW

(Guidance notes on the use of this form are printed on page 2)

ISSUED BY: Structura Ltd.

(Construction Review Firm)

TO: The Hay Family Trust

(Owner/Developer)

TO BE SUPPLIED TO: Christchurch City Council

(Building Consent Authority)

IN RESPECT OF: Structural earthquake repairs

(Description of Building Work)

AT: 240 Annex Rd, Christchurch.

(Address)

..... LOT ..... DP ..... SO .....

Structura Ltd has been engaged by The Hay Family Trust

(Construction Review Firm)

To provide  CM1  CM2  CM3  CM4  CM5 (Engineering Categories) or  observation as per agreement with owner/developer

or  other inspection at completion of structural works services

(Extent of Engagement)

in respect of clause(s) B1 of the Building Code for the building work described in

documents relating to Building Consent No. nil and those relating to

Building Consent Amendment(s) Nos. nil...issued during the

course of the works. We have sighted these Building Consents and the conditions of attached to them.

Authorised instructions / variations(s) No. SN001 to SN004 (copies attached)

or by the attached Schedule  have been issued during the course of the works.

On by the basis of  this  these review(s) and information supplied by the contractor during the course of the works and on behalf of the firm undertaking this Construction Review, I believe on reasonable grounds that  All  Part only of the building works have been completed in accordance with the relevant requirements of the Building Consent and Building Consent Amendments identified above, with respect to Clause(s) B1 of the Building Code.

I also believe on reasonable grounds that the persons who have undertaken this construction review have the necessary competency to do so.

I, Zoran Rakovic am:  CPEng No. 190397  
(Name of Construction Review Professional)

Reg Arch No. ....

I am a Member of:  IPENZ  NZIA and hold the following qualifications: BE, MBA.

The Construction Review Firm issuing this statement holds a current policy of Professional Indemnity Insurance no less than \$200,000\*.

The Construction Review Firm is a member of ACENZ:

SIGNED BY Zoran Rakovic . ON BEHALF OF Structura Ltd

Date: 27 March 2014

Signature: 

Note: This statement shall only be relied upon by the Building Consent Authority named above. Liability under this statement accrues to the Design Firm only. The total maximum amount of damages payable arising from this statement and all other statements provided to the Building Consent Authority in relation to this building work, whether in contract, tort or otherwise (including negligence), is limited to the sum of \$200,000\*.

This form is to accompany Forms 6 or 8 of the Building (Form) Regulations 2004 for the issue of a Code Compliance Certificate.

Project Number	S0054	Date	3/12/13
Project Name	240 Annex Rd		
Issued by	ZRakovic, CPEng	Page	1 of 1

Steel fabricator's RFI #1:

1) Conflict with door - we believe 250UB should be on the other side of panel, Please send us entire model so we can review,

2) Instead of bolts through panels, use M16 Spatec anchors, 100 embedment.

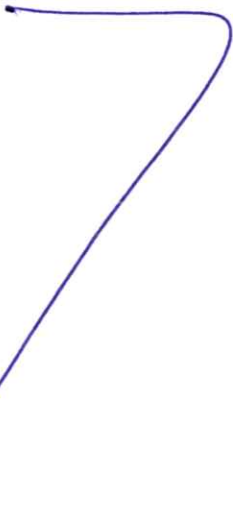

Project Number	S0054	Date	18/12/2013
Project Name	240 Annex Rd		
Issued by	Z Rakovic, CP Eng	Page	1 of 2

① Delete Spatec anchors and use M16 8.8 bolts through panel, as shown below.

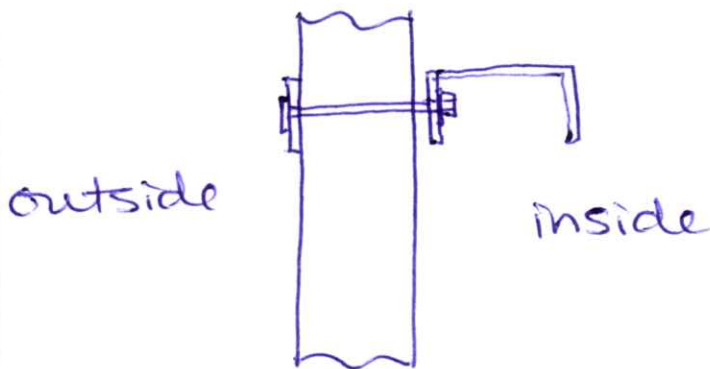

- Bolt head on the outside.
- Use Butyl Mastic to seal around bolt and washer

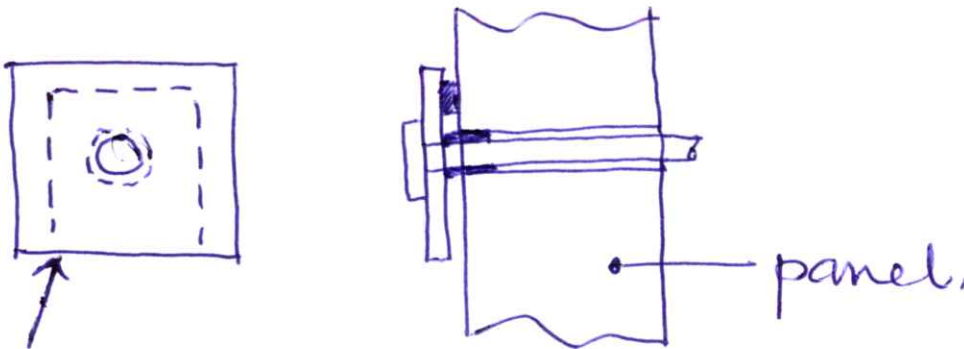

75x5 HDG600  
washer (outside)

② We have no objections to the proposed fixing at Foxair door,

Project Number	50054	Date	18/12/13
Project Name	240 Annex Rd		
Issued by	Z Rakout, CP Eng	Page	2 of 2

③ Fixings into South-East wall (boundary to adjacent building) shall be M16 Hilti HIT 500 epoxy anchors, 100 embedment.

④ Similarly, fixings to "curved" panels on the front shall be M16 Hilti HIT 500, 200 embedment.

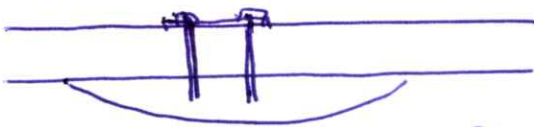

Plan - indicative,

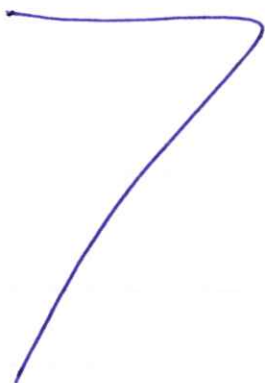

Zoran

0059

Structural Site Note No. 003

Project Number	S0054	Date	18/12/13
Project Name	240 Annex Rd		
Issued by	Zorano Cheng	Page	1 of 2

- RFI #2, #3 - see next page
- RFI #4 - remove existing PFC and install new structures as per drawings.

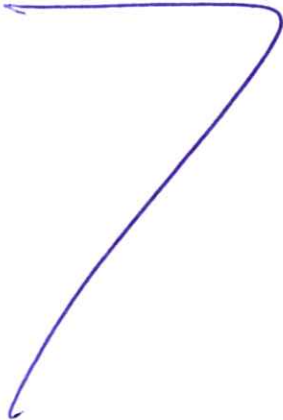

Zoran

RFI #2, #3

(D)

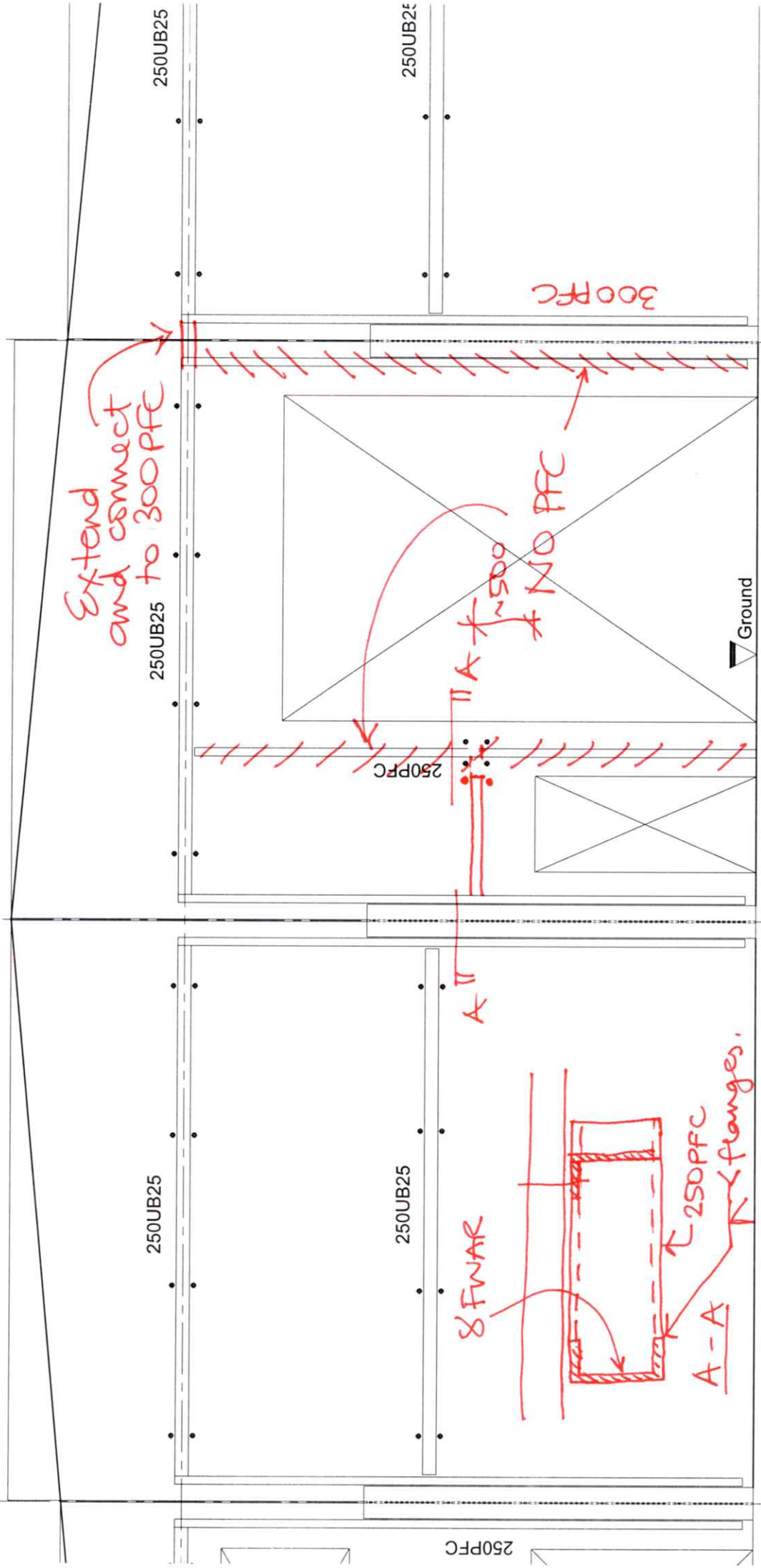

Grid 1/D

18/12/13.

Project Number	S0054	Date	27/3/2014
Project Name	240 Annex Rd repairs		
Issued by	ZRakovic, CP Eng	Page	1 of 1

We have inspected completed structural repair works on 24/3/14 and have no objections.

Zoran